

### Feature

- Output port compression 20V.
- Built-in voltage-regulator tube, only a resistance needed to add to IC VDD feet when under 24V power supply.
- 256 Gray-scale adjustable and scan frequency is more than **2KHz**.
- Built in signal reshaping circuit, to ensure waveform distortion do not accumulate after wave reshaping to the next driver
- Built-in electrify reset circuit and power-down reset circuit.
- Cascading port transmission signal by single line.
- Any two point the distance less than 5 Meters' transmission signal without any increase circuit.
- When the refresh rate is 30fps, the cascade number is at least 1024 pixels.
- Send data at speed of 800Kbps.

### Applications

- LED full color decorative lighting, such as LED string, LED strip, LED module etc.
- Indoor/outdoor LED video or irregular screen.
- LED consumer electronics.

### General description

The WS2811 is 3 output channels special for LED driver circuit. Its internal includes intelligent digital port data latch and signal reshaping amplification drive circuit. Also include a precision internal oscillator and a 12V voltage programmable constant current output drive. In the purpose of reduce power supply ripple, the 3 output channels designed to delay turn-on function.

IC use single NZR communication mode. After the chip power-on reset, the DIN port receive data from controller, the first IC collect initial 24bit data then sent to the internal data latch, the other data which reshaping by the internal signal reshaping amplification circuit sent to the next cascade IC through the DO port. After transmission for each chip, the signal to reduce 24bit. IC adopt auto reshaping transmit technology, making the chip cascade number is not limited the signal transmission, only depend on the speed of signal transmission.

The data latch of IC depend on the received 24bit data produce different duty ratio signal at OUTF, OUTG, OUTB port. All chip synchronous send the received data to each segment when the DIN port input a reset signal. It will receive new data again After the reset signal finished. Before a new reset signal received, the control signal of OUTF, OUTG, OUTB port unchanged. IC sent PWM data that received justly to OUTF, OUTG, OUTB port, after receive a low voltage reset signal the time retain over **280μs**.

We offer TWO package SOP8 and MSOP8.



### PIN configuration

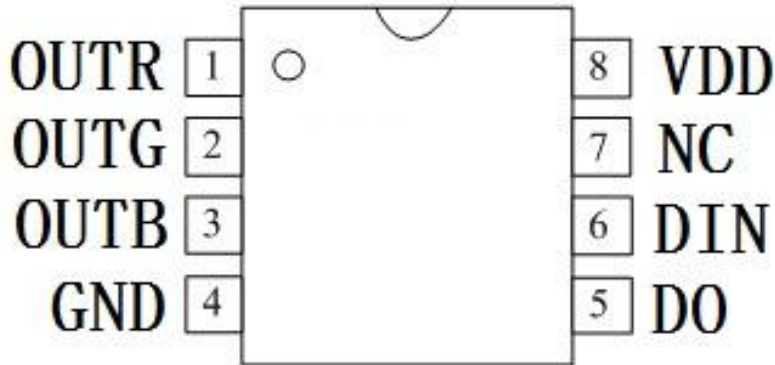

### PIN function

NO.	Symbol	PIN	Function description
1	OUTR	LED Driver Output	Output of RED PWM control
2	OUTG	LED Driver Output	Output of GREEN PWM control
3	OUTB	LED Driver Output	Output of BLUE PWM control
4	GND	Ground	Data & Power Grounding
5	DO	DO	Data Output
6	DIN	Data Input	Control data input
7	NC	NC	NC
8	VDD	Power Voltage	IC power supply

### Absolute Maximum Ratings (T<sub>A</sub>=25°C, V<sub>SS</sub>=0V, unless otherwise noted.)

Parameter	Symbol	Ratings	Unit
Power Supply Voltage	V <sub>DD</sub>	+3.5~+5.5	V
R/G/B Channel Output Port Withstand Voltage	V <sub>out</sub>	20	V
Logical Input Voltage	V <sub>I</sub>	V <sub>DD</sub> -0.7~V <sub>DD</sub> +0.7	V
Operation Temperature	T <sub>opt</sub>	-25~+85	°C
Storage Temperature Range	T <sub>stg</sub>	-40~150	°C

Note: If the voltage on the pins exceeds the maximum ratings may cause permanent damage to the device.



**Electrical Characteristics** ( $T_A=-20\sim+70^{\circ}\text{C}$ ,  $V_{DD}=4.5\sim 5.5\text{V}$ ,  $V_{SS}=0\text{V}$ , unless otherwise specified)

Parameter	Symbol	Min	Tpy	Max	Unit	Conditions
R/G/B Low voltage output current	$I_{OL}$	15.5	16.5	17.5	mA	
Low voltage output current	$I_{dout}$	10	—	—	mA	$V_o=0.4\text{V}$ , $D_{OUT}$
Input current	$I_I$	—	—	$\pm 1$	$\mu\text{A}$	$V_I=V_{DD}/V_{SS}$
Input voltage level	$V_{IH}$	$0.7V_{DD}$	—	—	V	$D_{IN}$ , SET
	$V_{IL}$	—	—	$0.3 V_{DD}$	V	$D_{IN}$ , SET
Hysteresis voltage	$V_H$	—	0.35	—	V	$D_{IN}$ , SET

**Switching characteristics** ( $T_A=-20\sim+70^{\circ}\text{C}$ ,  $V_{DD}=4.5\sim 5.5\text{V}$ ,  $V_{SS}=0\text{V}$ , unless otherwise specified)

Parameter	Symbol	Min	Tpy	Max	Unit	Condition
Oscillation frequency	$F_{osc}$	—	800	—	KHz	—
Transmission delay time	$T_{PLZ}$	—	—	300	ns	$CL=15\text{pF}$ , $D_{IN}\rightarrow D_{OUT}$ , $RL=10\text{K}\Omega$
Fall time	$T_{THZ}$	—	—	120	$\mu\text{s}$	$CL=300\text{pF}$ , $OUTR/OUTG/OUTB$
Data transmission rate	$F_{MAX}$	600	—	—	Kbps	Duty ratio 50%
Input capacity	$C_I$	—	—	15	pF	—

### Data Transfer Time

T0H	0 code, high voltage time	220ns~380ns
T1H	1 code, high voltage time	580ns~1us
T0L	0 code, low voltage time	580ns~1us
T1L	1 code, low voltage time	580ns~1us
RES	Frame unit, low voltage time	>280 $\mu\text{s}$



### Sequence Chart

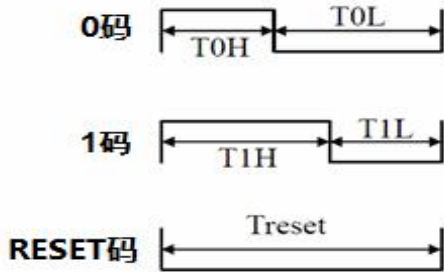

### Cascade Method

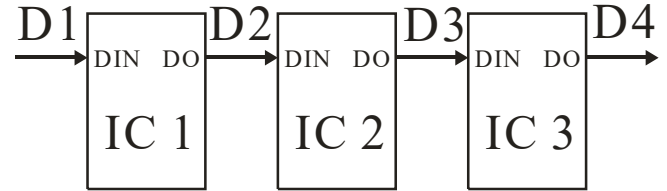

### Data Transmission Method

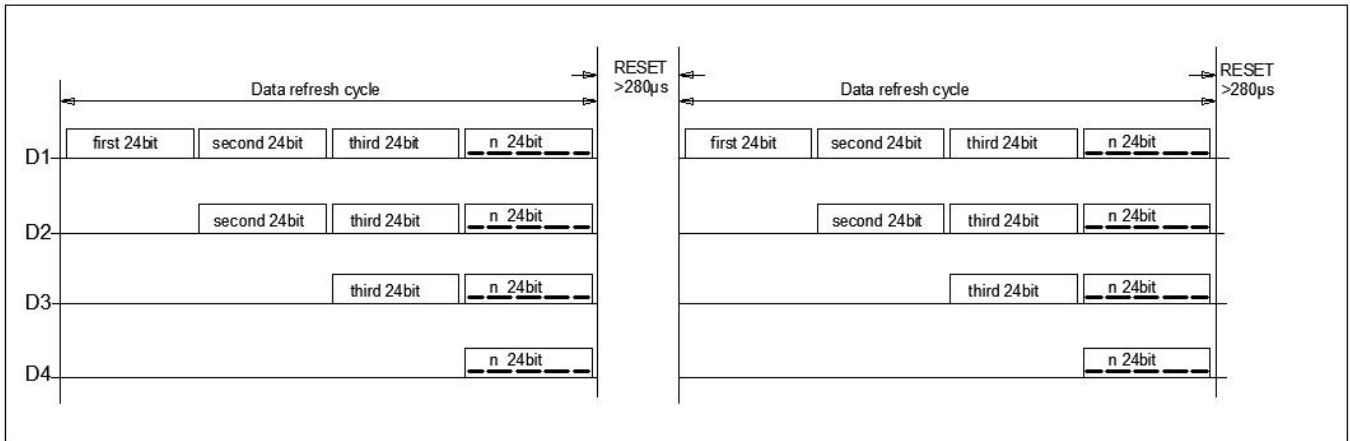

Note: The data of D1 is send by MCU, and D2, D3, D4 through IC internal reshaping amplification to transmit.

### Composition of 24bit Data

R7	R6	R5	R4	R3	R2	R1	R0	G7	G6	G5	G4	G3	G2	G1	G0	B7	B6	B5	B4	B3	B2	B1	B0
----	----	----	----	----	----	----	----	----	----	----	----	----	----	----	----	----	----	----	----	----	----	----	----

Note: Data transmit in order of RGB, high bit data at first.

### Typical Application Circuit

#### 1. Supply voltage=5V, 1 LED for each channel

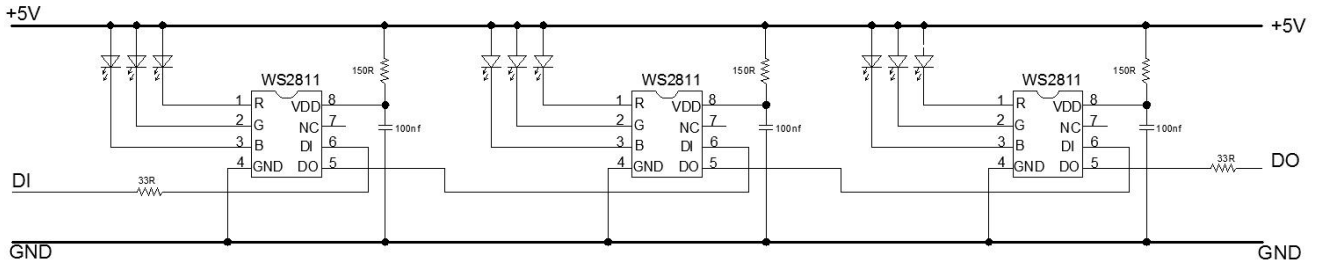

#### 2. Supply voltage=12V, 3 LED for each channel

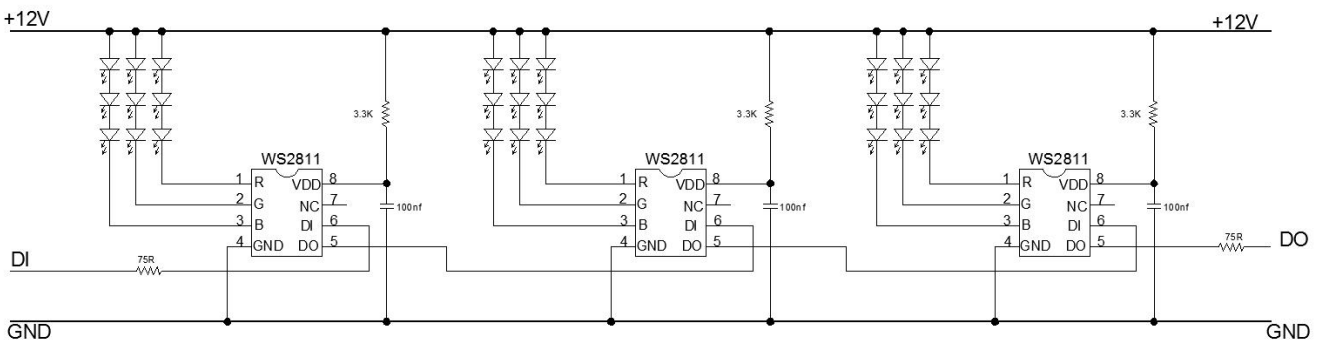

#### 3. Supply voltage=24V, 6 LED for each channel

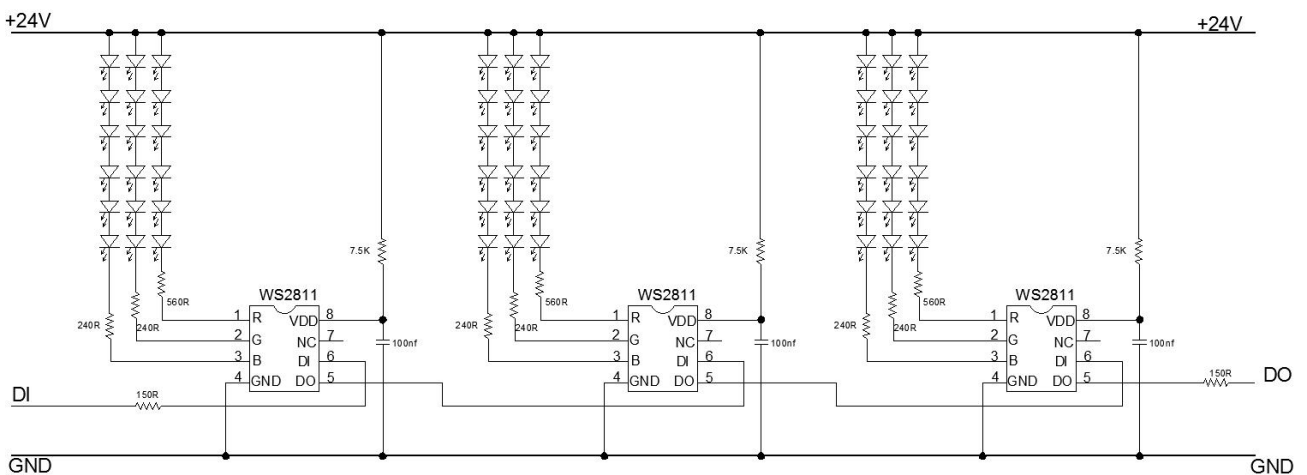

### Package information

- SOP8 Package

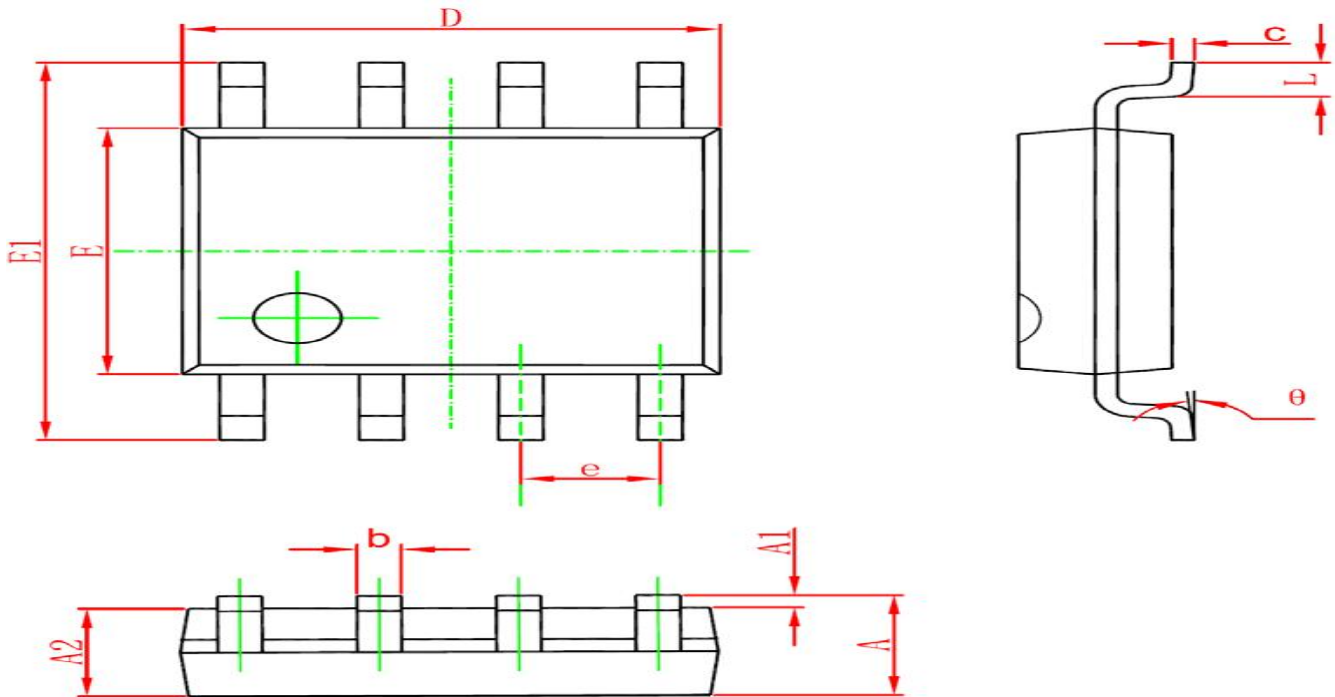

Symbol	Dimensions In Millimeters		Dimensions In Inches	
	Min	Max	Min	Max
A	1.350	1.750	0.053	0.069
A1	0.100	0.250	0.004	0.010
A2	1.350	1.550	0.053	0.061
b	0.330	0.510	0.013	0.020
c	0.170	0.250	0.006	0.010
D	4.700	5.100	0.185	0.200
E	3.800	4.000	0.150	0.157
E1	5.800	6.200	0.228	0.244
e	1.270		0.050	
L	0.400	1.270	0.016	0.050
θ	0°	8°	0°	8°



- MSOP8 Package

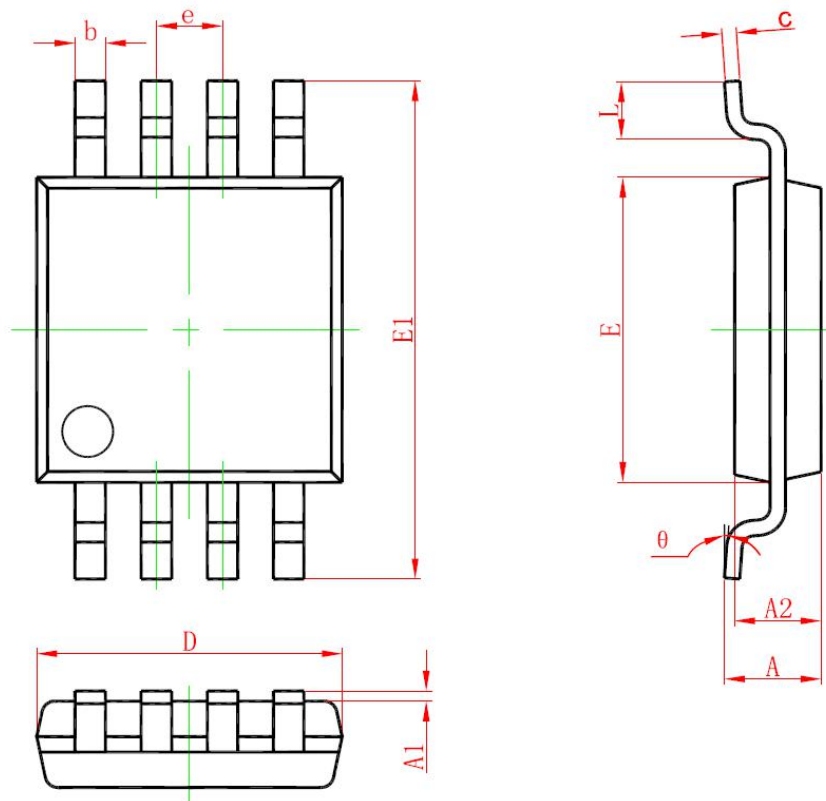

Symbol	Dimensions In Millimeters		Dimensions In Inches	
	Min	Max	Min	Max
A	0.820	1.100	0.032	0.043
A1	0.020	0.150	0.001	0.006
A2	0.750	0.950	0.030	0.037
b	0.250	0.380	0.010	0.015
c	0.090	0.230	0.004	0.009
D	2.900	3.100	0.114	0.122
e	0.650(BSC)		0.026(BSC)	
E	2.900	3.100	0.114	0.122
E1	4.750	5.050	0.187	0.199
L	0.400	0.800	0.016	0.031
$\theta$	0°	6°	0°	6°

### Modify Records

Version №	Status Bar	Modify Content Summary	Date	Reviser	Approved
V1.0	N	New	20170523	Shen JinGuo	Yin HuaPing
V1.1	M	Absolute Maximum Ratings	20171009	Shen JinGuo	Yin HuaPing
V1.2	M	Switching characteristics	20171108	Shen JinGuo	Yin HuaPing
V1.3	M	Maximum ratings, Data transfer time, Main feature, General description	20182207	Shen JinGuo	Yin HuaPing
V1.4	M	Logical Input Voltage, T1L timing	20180910	Shen JinGuo	Yin HuaPing
V1.5	M	Typical Application Circuit	20190920	Shen JinGuo	Yin HuaPing

Remarks: Initial version: V1.0; Version number plus "0.1" after each revision;

Status bar: N--New, A--Add, M--Modify, D--Delete.